



1.800.294.4667

www.hoopsincorporated.com

Hoops Pro Dunk® Bronze Installation Instructions

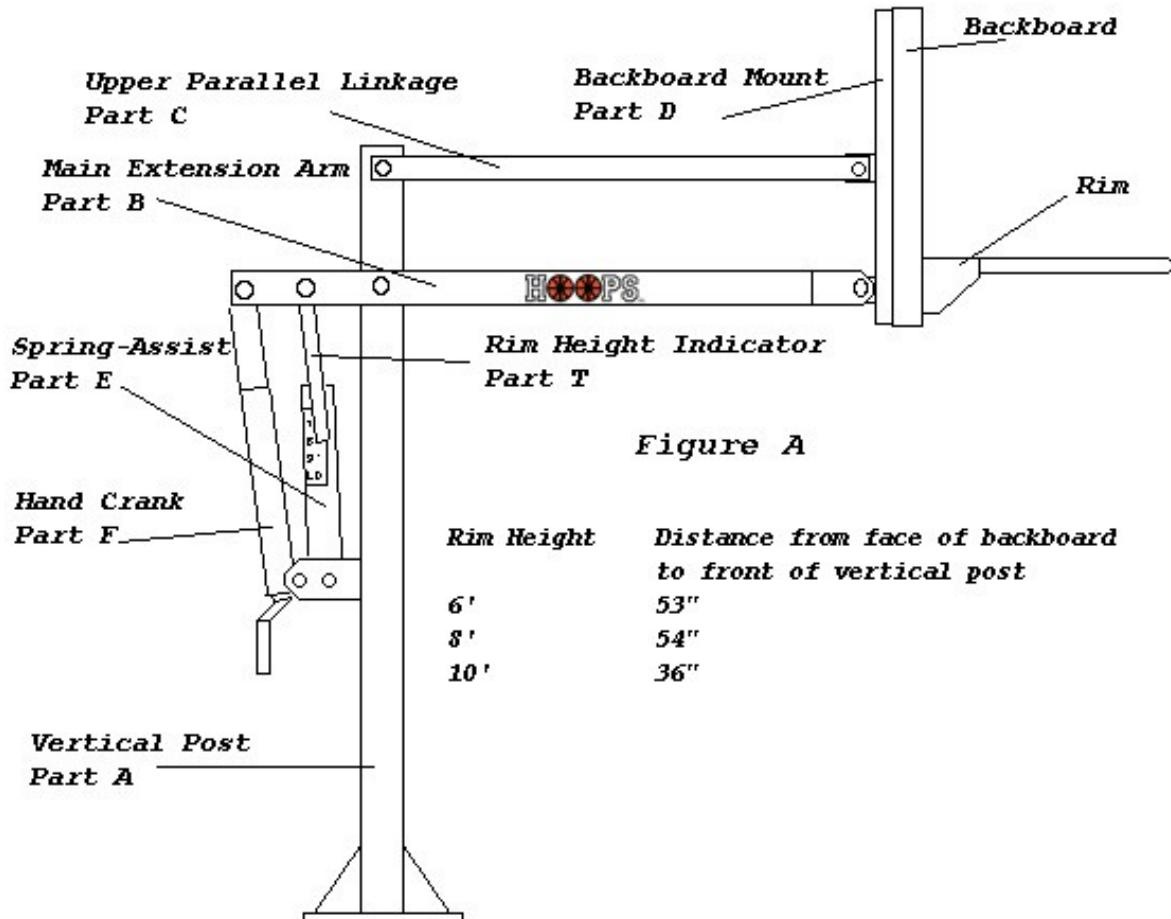

Figure A

Bill of Materials

- | | | |
|---------------------------------------|--------------------------------------|---------------------------|
| A (1) Vertical Post | I(1) 16mm x 27.94cm (11") Hex Bolt | Q(8) 8mm Lockwasher |
| B(1) Main Extension Arm | J(8) 16mm Locknut | R(8) 8mm Hex Nut |
| C(2) Parallel Linkage | K(4) 16mm Anchor Bolt | S(1) Rim Height Sticker |
| D(1) H-Frame Backboard Mount | L(12) 16mm Hex Nut | T(1) Rim Height Indicator |
| E(1) Spring-Assist Cartridge | M(1) Anchor Footing Template | |
| F(1) Crank Adjustment Cylinder | N(4) Anchor Footing Rebar | |
| G(2) 14mm x 11.43cm (4 1/2") Hex Bolt | O(8) 8mm x 2.54cm (1") Machine Screw | |
| H(5) 16mm x 25.4cm (10") Hex Bolt | P(8) 8mm Flat Washer | |

NOTE: Immediately unpack all components and cross check against bill of materials. Report any shortages to Hoops customer service at 281.351.9822.

1. CAUTION: YOUR SPRING-ASSIST CARTRIDGE IS SHIPPED UNDER TENSION. DO NOT REMOVE CARDBOARD SPREADER TUBE FROM SPRING-ASSIST UNTIL INSTRUCTED TO DO SO. FOLLOW INSTRUCTIONS CAREFULLY.
2. Choose the proper location to dig for the concrete footing. Use the distance chart in figure A to help you make your decision. When choosing the exact position to dig, make sure to maximize the amount of playing surface while minimizing possible driveway obstruction.
3. Dig hole 36" deep and 20" square. Be sure to bell out the bottom 12" of the hole to give added stability to the footing. NOTE: If you live in an area where the frost line is below 36" it is advisable to dig to normal frost line. Do not cheat on the hole size, it is imperative that the hole be a minimum of 36" deep and 20" square!
4. Assemble the anchor kit as shown in figure B. First thread a 16mm hex nut (L) 6.35cm (2 1/2") of the way on to each J-Bolt (K). Place the threaded end of each J-Bolt through the 4 holes located in the anchor template (M). Then thread a second 16mm nut on to each J-Bolt until tight against the template, making sure to keep the J-Bolt hooks pointing in toward the center of the template.
5. For this step you will need: Level; Broomstick; Tape Measure. The 36" x 20" anchor footing will require approximately 1/3 yard of 3000 psi concrete (18-20 60# sacks of premix concrete). More will be needed if you dig a larger hole. Make certain that you have enough concrete to finish the job. Allowing a portion to dry while you purchase more concrete will weaken the footing.
6. Mix the concrete according to the instructions on the bag. It is better to mix it slightly wet than too dry. Fill the hole full to ground level with as little time between batches as possible. Insert the broomstick in 3 or 4 different places and vibrate up and down to settle the concrete. Submerge the (4) anchor footing rebar pieces (N) into the center of the hole spaced evenly. Next set the anchor bolt assembly into the wet concrete, vibrate it as it goes in to make sure the concrete fills in around the J-Bolt hooks. Make sure the template is pressed firmly against the top of the wet concrete. Use the level to ensure that it is level in all directions. Additionally, the center line of the J-Bolts must be parallel with the edge of the playing surface. (See figure C)

STOP HERE! Allow footing to cure for seven days before proceeding.

7. Take off the top 16mm nuts from the J-Bolts.
8. Loosen the 4 16mm nuts from the J-Bolts. Leave metal template in place
9. Place the vertical post (A) down over the footing making sure not to damage the J-Bolt threads. Using the final (4) 16mm hex nuts, bolt down post finger tight with two metal ears to the rear.
10. Level the vertical post by adjusting the 16mm nuts located underneath the base plate. Then tighten top nuts against the top side of the base plate.
11. Slide the main arm (B) over the top of the vertical post and attach to the lower pivot tube with a 16mm x 25.4cm hex bolt (H) and 16mm locknut (J).
12. Slide the hole located in the rim height indicator (T) over one of the second set of welded tubes in the main arm. Attach the spring-assist cartridge (E) to the second set of attachment holes on both the main arm and the vertical post

welded tabs utilizing a 16mm x 25.4cm hex bolt (H) and a 14mm x 11.43cm hex bolt (G). Tighten each with a 16mm locknut (J). The rim height indicator should now hang freely along side the spring-assist cartridge.

13. Next attach the hand crank adjustment cylinder (F) using a 16mm x 25.4cm hex bolt (H) and 14mm x 11.43cm hex bolt (G). Tighten each with a 16mm locknut (J). Next, remove and discard the blue plastic spreader tube from the spring-assist cartridge.

14. Attach parallel linkages (C) to vertical post with 16mm x 25.4cm hex bolt (H) and 16mm locknut (J). Attention: It does not matter which end of the parallel link you attach to the vertical post.

Caution: Injury may occur if linkages are allowed to fall off main arm during assembly.

15. Next, assemble the H-Frame backboard mounting (D) to the backboard as shown in figure D. Use the (8) 8mm x 2.54cm machine screws (O), (8) 8mm flat washer (P), (8) 8mm lockwasher (Q), (8) 8mm hex nuts (R).

16. Mount the H-Frame/Backboard assembly lower pivot tube first to the main arm using (1) 16mm x 27.94cm hex bolt (I) and (1) 16mm locknut (J). Next, attach the upper H-Frame pivot tube to the upper parallel linkages using (1) 16mm x 25.4cm hex bolt (H) and (1) 16mm locknut (J).

17. Check face of backboard to see if it is level forward and back. If it is out of level, correct it by adjusting the 16mm nuts located underneath the vertical post base plate.

18. Prior to installing the rim, locate four plastic and steel spacers. Insert them into four rim holes in backboard. Now install rim using bolts, nut, and washers provided in rim carton. Without these important spacers the backboard could break when tightening the rim fasteners. Do not proceed with rim installation without these spacers!

19. Mount the rim to the H-Frame/Backboard assembly using the hardware supplied in the rim box. Use level to make sure rim is level side to side before tightening nuts.

20. After everything is square, make sure all nuts have been tightened. However, do not overtighten, if unit is difficult to crank up and down the main pivot nuts are probably too tight.

21. To apply the rim height sticker (S), first use a tape measure to crank rim up to exactly 10' from the playing surface. Use a pencil to make a mark on the spring-assist outer tube where the rim height indicator stops. Then, peel and apply sticker to outside of spring-assist cartridge lining up the pencil mark with the 10' mark on the sticker. See Figure A for a diagram of a completed height indicator assembly.

Note: It is advisable to wait up to two weeks to allow the anchor footing to fully cure before aggressive play

Figure B

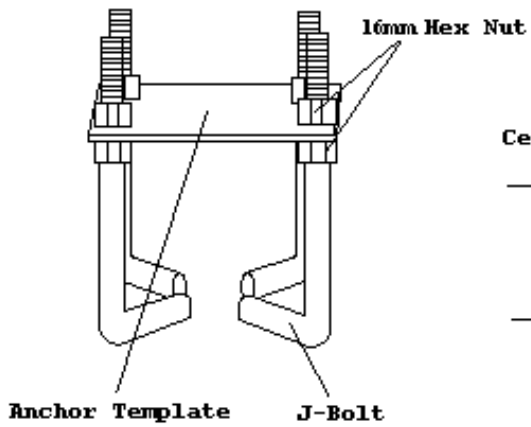

Figure C

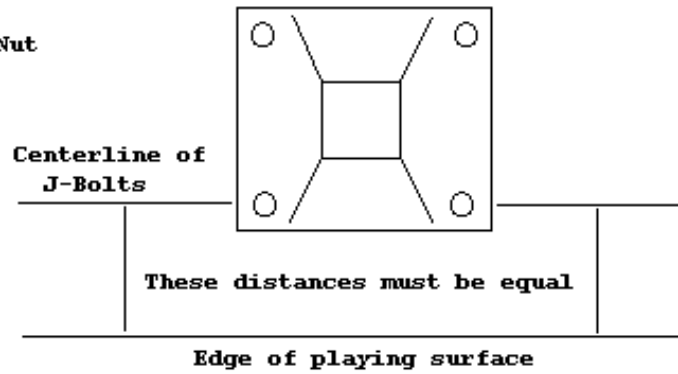

Figure D

